

ECOHOOG®

EH1500-TWS Tracked Windshifter

Incorporating air technology, the Ecohog EH1500-TWS Windshifter facilitates fraction separation based on desired density. The onboard VSD controlled EH-81 Airhog suction fan removes light and superlight contaminants and the windshifter unit separates the heavy fraction from the light fraction. Opting for a head drum magnet for the recovery of ferrous metals, the EH1500-TWS can achieve a four way split of 10mm-300mm material depending on bulk mass density. This unit has a range of features that position's it most desirable in the marketplace.



KEY FEATURES

Tracked option for ease of transportation and site mobility

Up to 4 way split enabling separation of super light, light and heavy fraction and recovery of ferrous metals

10mm - 300mm separation depending on bulk mass density

Onboard genset

Vibrating Pan Feeder for an evenly distributed material infeed

Integrated lights conveyor suitable for stockpiling

Integrated heavies conveyor

Energy efficient motors

Low maintenance

Low operational costs

SUITABLE FOR

Cleaning Compost / Compost Oversize

Construction & Demolition waste (C&D)

Construction & Industrial waste (C&I)

Glass (MRF) Clean up

Trommel Fines

Waste Wood processing

RDF / SRF

Green Waste

CRAWLER TRACKS AND ONBOARD GENERATOR NOW AVAILABLE ON ECOHOOG WINDSHIFTER UNITS



Quarry Road | Carrickmore
Omagh | Co. Tyrone | N.I.

T (UK) +44 (0)28 8076 1295

T (USA) 347 630 9822

info@ecohogwindshifters.com

ecohogwindshifters.com

TECHNICAL DATA

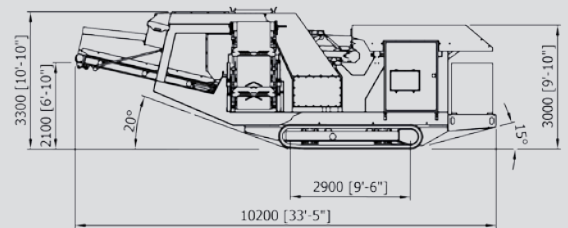
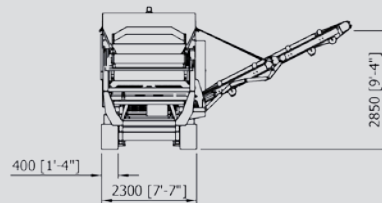
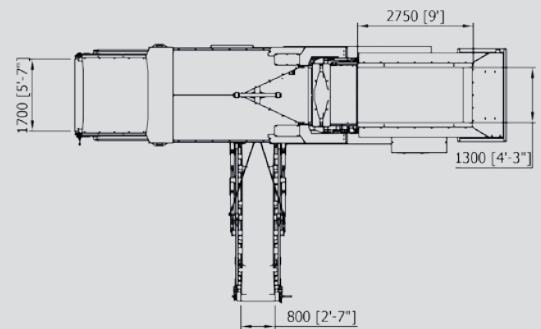
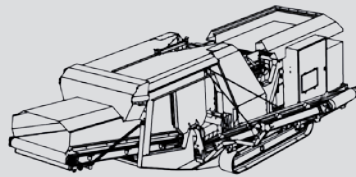
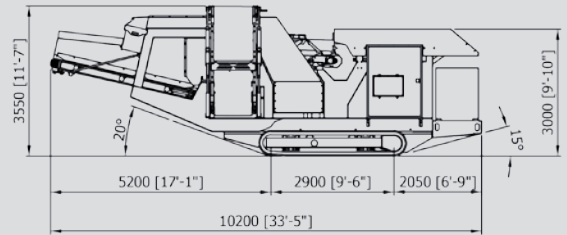
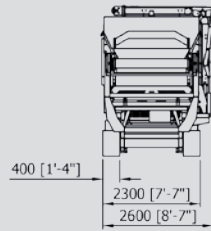
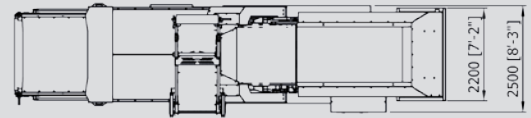
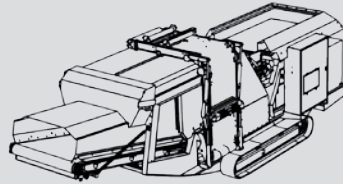

SPECIFICATION

EH1500-TWS

Weight 15T (approx.)
 Transport Length (10,200mm)
 Transport Height (3550mm)
 Transport Width (2600mm)
 Operating Length (9700mm)
 Operating Height (3400mm)
 Operating Width (10,200mm)

Vibrating Pan Feeder

2 x 1.5kW out of balance motors.
 Pan Length (2500mm)
 Pan Width (1300mm)

Radial Blower Fans

Centrifugal medium pressure fans and straight blade impeller
 2x 7.5kW IP55 geared motors VSD
 Max speed: 2900rpm
 Max air flow: 0-3780m³/h.
 Sound Pressure: 87db (A)

Accelerator Conveyor

4kW IP55 geared motor VSD
 Belt Length (2550mm)
 Belt Working Width (1500mm)

Transfer Conveyor 1

(Heavies)
 4kW IP55 geared motor
 Belt Length (1800mm)
 Belt Working Width (800mm)

Stockpiling Conveyor 1

(Heavies)
 5.5kW IP55 geared motor VSD
 Belt Length (4200mm)
 Belt Working Width (800mm)

Stockpiling Conveyor 2

(Lights)
 5.5kW IP55 geared motor
 Belt Length (3400mm)
 Belt Working Width (1500mm)

Mild Steel Separation Drum

3kW IP55 geared motor VSD

EH81 AirHog

11kW IP55 geared motor VSD
 Max speed: 2800rpm

Electrics

Manual start/stop of each motor
 Motor disconnect switches for maintenance

Motor run & trip illumination on panel doors

Prestart siren and dual channel emergency stop

Power Supply

100KVA Diesel Generator

Hydraulics

Power Source (30kW Power pack) unit to power track set and conveyor cylinders

Hydraulic tank capacity: 250 L

UL Certification

All products supplied by Ecohog will be built to the highest specification and control panels will be UL Approved for the USA and Canadian markets.

