

# ECOHOOG®

## ESD-1800S Magnetic Scrap Drum

The ESD-1800S tackles separating large heavy scrap metal that need separated in advance of further processing to protect equipment and ensure better separation downstream. The large heavy scrap metal can also yield significant cash value depending on the type of material being processed. The standalone unit is designed with lifting eyes for craning to ensure ease of movement.

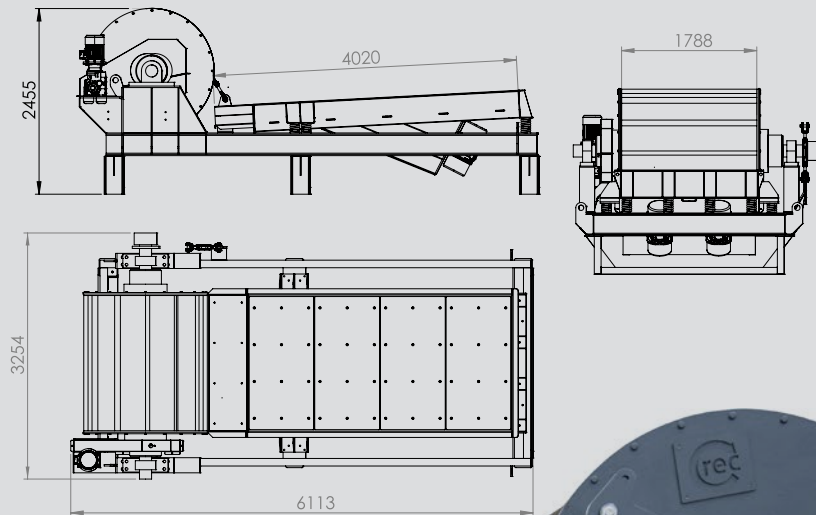
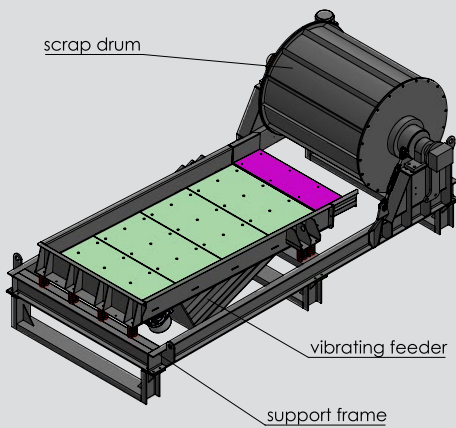

### KEY FEATURES

- 4M Vibrating Feeder
- Compact
- 1800mm Magnetic Scrap Drum
- Ease of Transport
- Low Maintenance
- High Throughput

### DIMENSIONS

Weight | 15 tonne (approx.)

#### Transport

6113mm length  
2455mm height  
3254mm width

#### Operating

6113mm length  
2455mm height  
3254mm width

### OPTIONAL EXTRAS

- available in 1000mm, 1200mm, 1500mm, & 2000mm length
- electro magnet options

Ecohog HQ  
Quarry Road | Carrickmore  
Omagh | Co. Tyrone | N.I.  
T (UK) +44 (0)28 8076 1295  
info@ecohog.com

